

Miniature Cable Assembly D-Sub15-Female



Note: The photo is for illustration purposes only.
Please refer to outline drawing

Features

- 0.11" (2.77mm) contact spacing.
- Standard D-Sub connector

Electrical Specifications

Parameter	Min.	Typ.	Max.	Units
Cable Length	150	200		mm
Current Rating			5	A
Voltage Rating			500	V
Insulation Resistance	1000			MΩ
Cable Gauge		20		AWG
Operational Temperature	-50		+85	°C
Contact Material	Copper Alloy			
Connectors	D -Sub 15-Female			

Outline Drawing

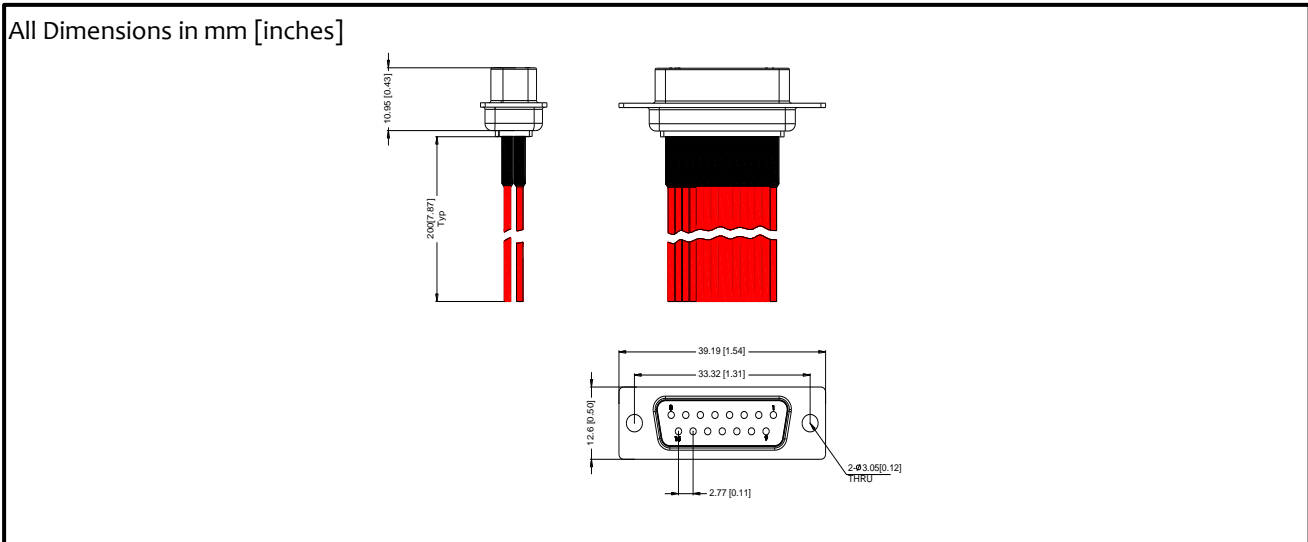

Important Notice

The information contained herein is believed to be reliable. RF-Lambda makes no warranties regarding the information contained herein. RF-Lambda assumes no responsibility or liability whatsoever for any of the information contained herein. RF-Lambda assumes no responsibility or liability whatsoever for the use of the information contained herein. The information contained herein is provided "AS IS, WHERE IS" and with all faults, and the entire risk associated with such information is entirely with the user. All information contained herein is subject to change without notice. Customers should obtain and verify the latest relevant information before placing orders for RF-Lambda products. The information contained herein or any use of such information does not grant, explicitly or implicitly, to any party any patent rights, licenses, or any other intellectual property rights, whether with regard to such information itself or anything described by such information. RF-Lambda products are not warranted or authorized for use as critical components in medical, life-saving, or life sustaining applications, or other applications where a failure would reasonably be expected to cause severe personal injury or death.