

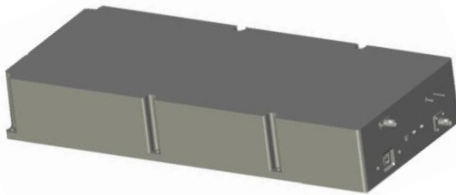

### RF Synthesizer – 0.039-44GHz Ultra Low Phase Noise USB Control

#### Summary

The RSYN01G44GA is an easy to use high frequency signal generator controlled through a standard USB port. Using advanced VCO and DDS based technology along with a temperature compensated crystal reference, it offers ultra-low phase noise (-129dBc/Hz at 1MHz offset 1GHz output) and high frequency resolution. The unit can also be locked to an external 10MHz reference source.



#### General Specifications

- Output Frequency Range: 0.039 ~ 44GHz
- Output Power Range: -20dBm to +10dBm
- Frequency Stability: +/-0.5ppm with internal reference
- Frequency Step Tuning Speed: <100us
- Tuning Step: 0.001Hz
- Phase Noise @10KHz offset -110dBc/Hz (@10GHz Output Frequency)
- Control Interface: USB

Electrical Specifications			
Frequency	39MHz-44GHz	Typical Output Power	10dBm
Frequency Stability	+/-0.5ppm	Output Power Tuning Range	31.5dB with 0.5dB step
Frequency Aging	+/- 3ppm (10 years)	Output Power Linearity	+/- 0.5dB
Reference Tuning Range	+/-100ppm	Output Power Accuracy	+/- 1.5dB
Tuning Step	0.001Hz	SFDR 1MHz Tuning Step	65dBc
Phase Noise @ 10GHz Typical	-116dBc/Hz (@10KHz) -117dBc/Hz (@100KHz) -118dBc/Hz (@1MHz) -140dBc/Hz (@10MHz)	2 <sup>nd</sup> Harmonic	-30dBc
Power Supply Voltage	Vcc = +15V Icc = 1300mA	3 <sup>rd</sup> Harmonic	-35dBc
USB Standard	USB 2.0	EXT Reference Power	0dBm to 10dBm

Ultra Low Phase Noise USB Control RF Signal Generator – 0.039-44GHz

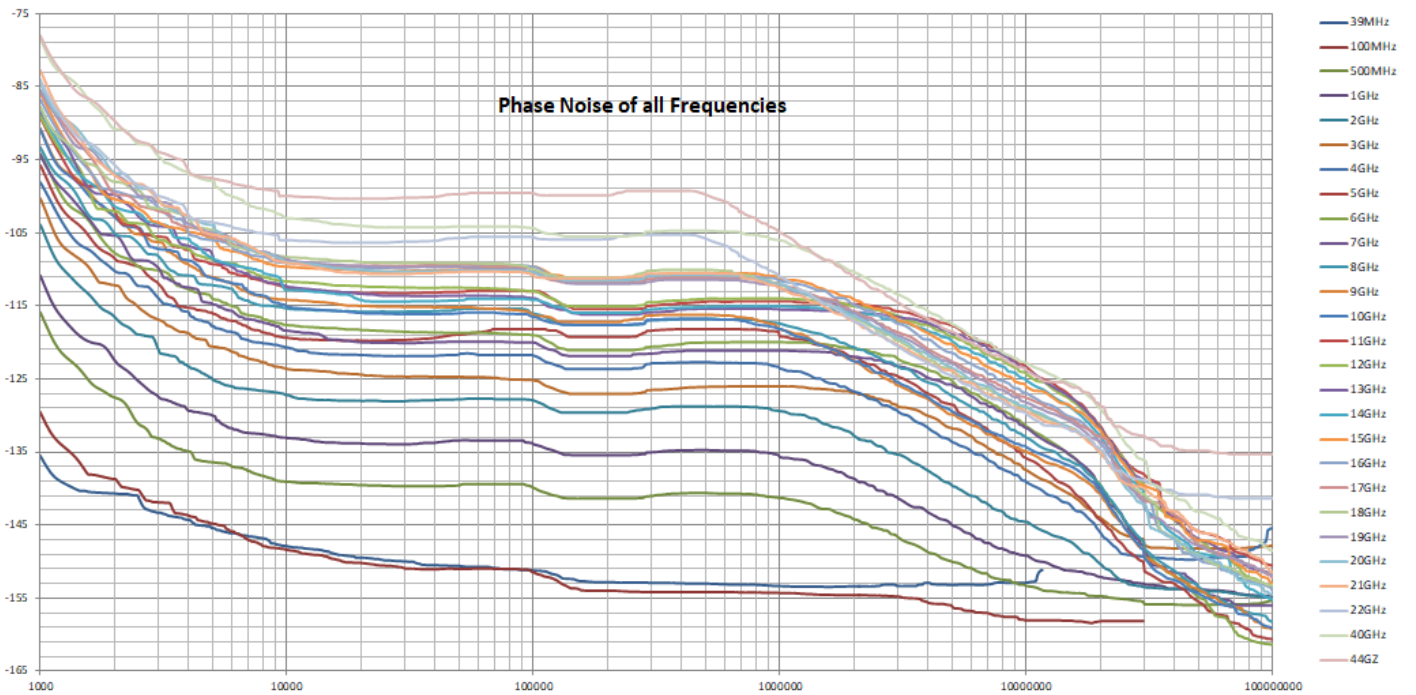
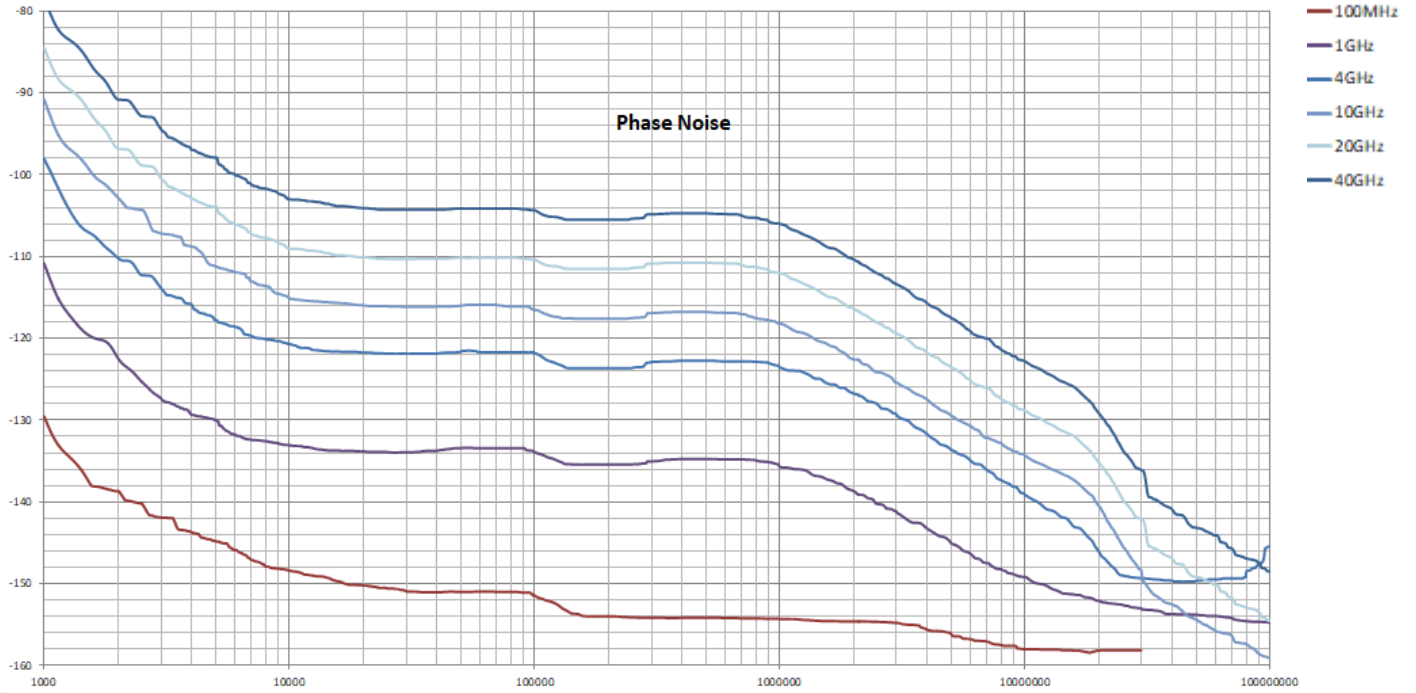

Ultra Low Phase Noise USB Control RF Signal Generator – 0.039-44GHz



## Phase Noise Comparison

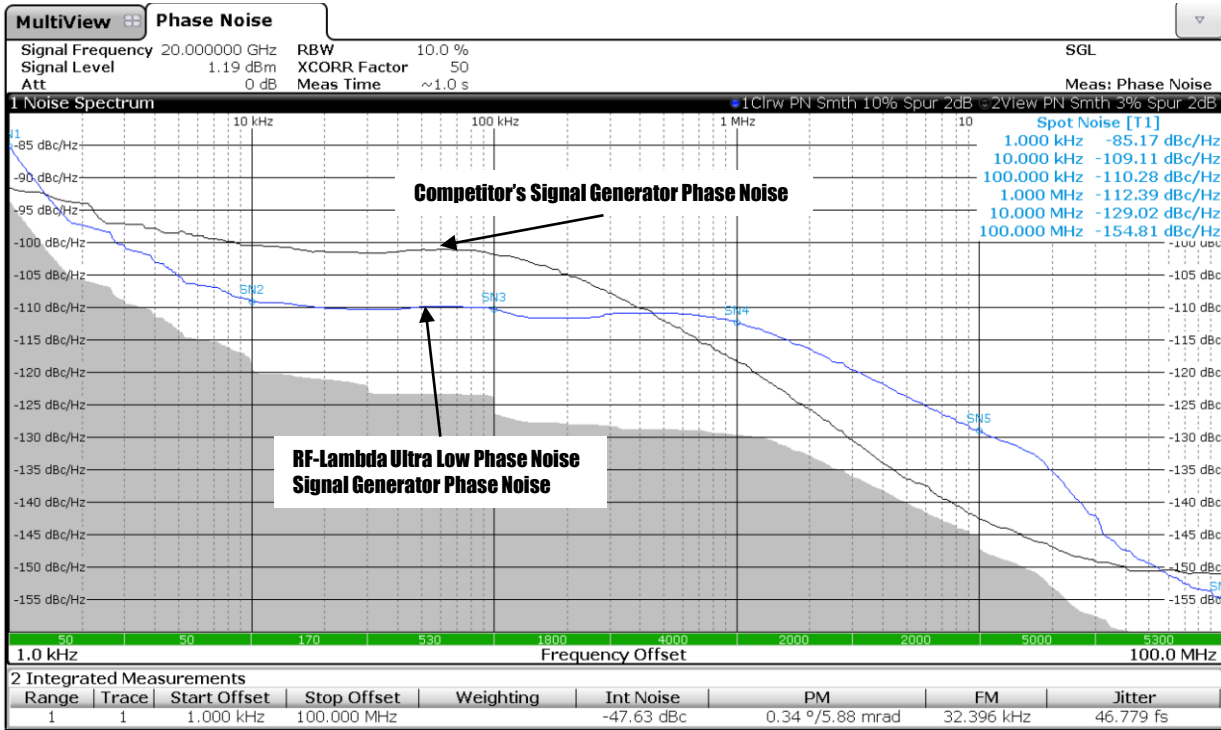

Video Instruction Link:

[http://www.rflambda.com/product\\_signalgenerator.jsp](http://www.rflambda.com/product_signalgenerator.jsp)

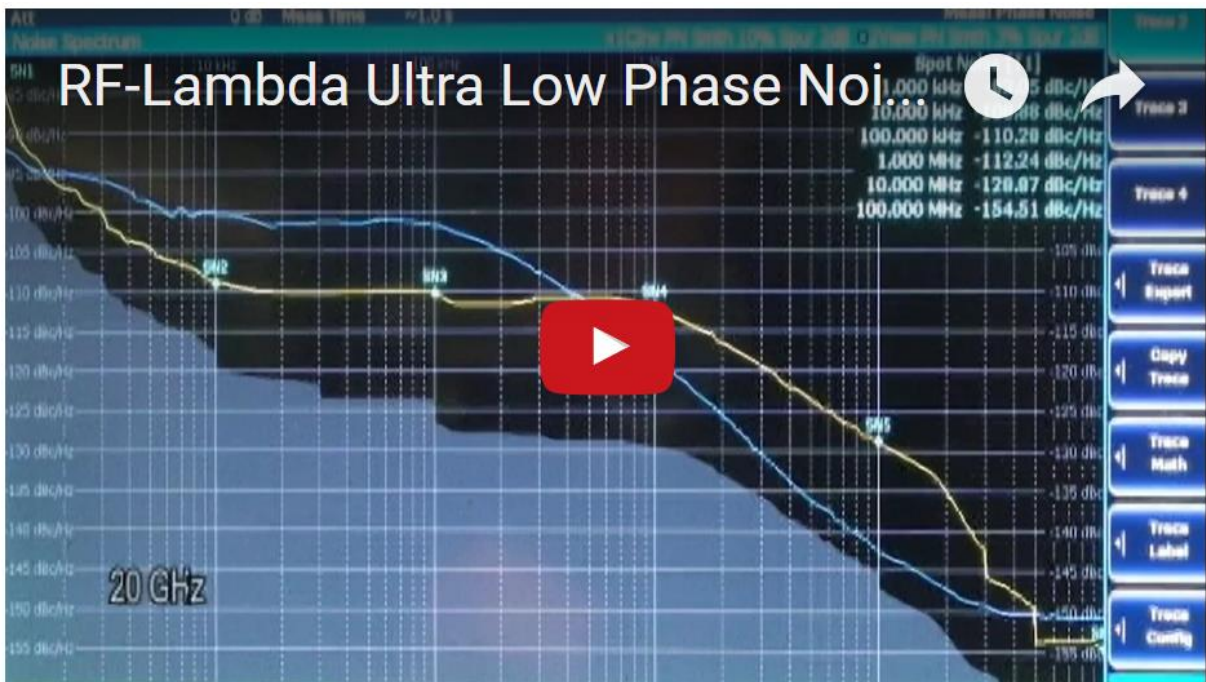

Ultra Low Phase Noise USB Control RF Signal Generator – 0.039-44GHz



### User Instructions:

1. Install the SW below on the control PC
  - a. Visual C++ Redistributable Packages for Visual Studio 2013  
<https://www.microsoft.com/en-us/download/details.aspx?id=40784>
  - b. Visual Studio 2010 Tools for Office Runtime  
<https://www.microsoft.com/en-us/download/details.aspx?id=48217>
  - c. Microsoft .NET Framework 4.6.2  
<https://www.microsoft.com/en-us/download/details.aspx?id=53344>

2. Install the USB Driver under this directory:  
\\RF-Lambda SG Utility\_Rev\_2.0\Installation Software\USB Driver \  
USBXpressInstaller\_x64.exe

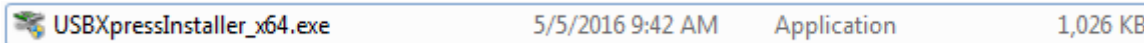

3. Open “RF-Lambda SG Utility\_Rev\_2.0.exe”  
\\RF-Lambda SG Utility\_Rev\_2.0\RF-Lambda SG Utility\_Rev\_2.0\  
RF-Lambda SG Utility\_Rev\_2.0.exe



4. The program will look like this:

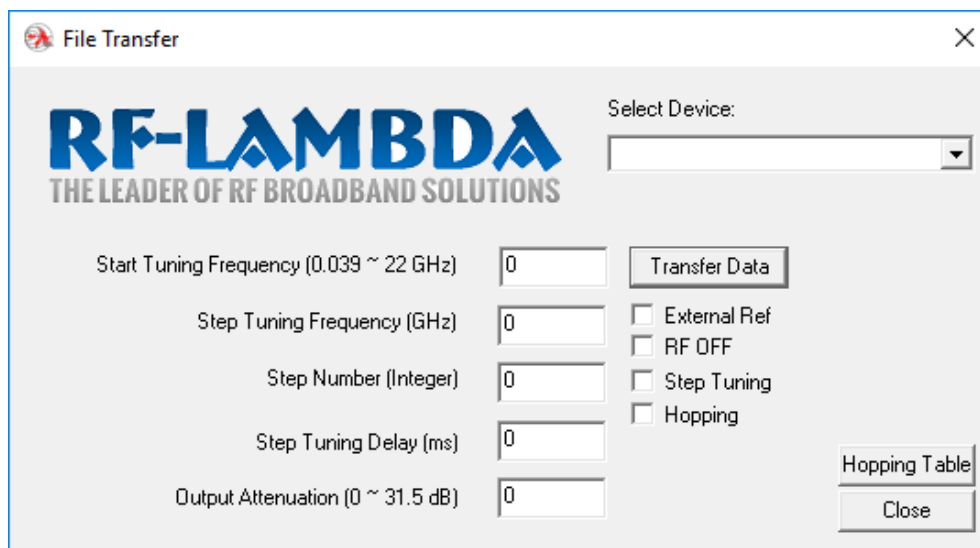



5. Turn on the +15V power supply. The part number, serial number, and revision number will show up in the top right corner.

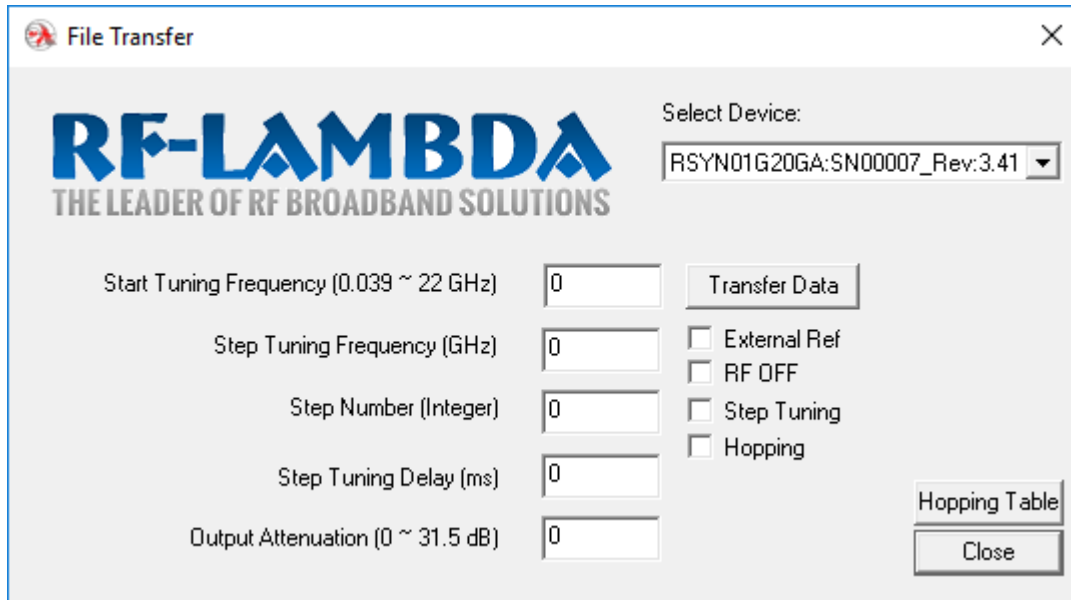

6. You can reduce the output power by entering an attenuation: (0.5dB to 31.5dB, 0.5dB per step, ex: 0.5dB, 1.0dB, 1.5dB... etc)

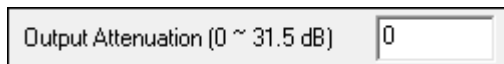

7. You can enable the external ref input by clicking here:

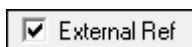

## Single Frequency Mode

a. Change the frequency (0.039 ~ 44GHz) here and then click Transfer Data:

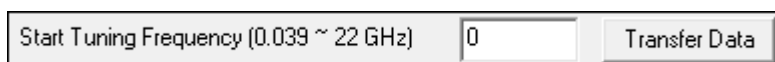



### Step Tuning Mode

$Tuning\ Frequency = Start\ Tuning\ Frequency + Step\ Tuning\ Frequency * Step\ Number\ (Integer)$

Example:

If you want 1,3,5,7,9 GHz frequency changing every 5000ms.

Start Tuning Frequency (0.039 ~ 22 GHz)	<input type="text" value="1"/>	<input type="button" value="Transfer Data"/>
Step Tuning Frequency (GHz)	<input type="text" value="2"/>	<input type="checkbox"/> External Ref
Step Number (Integer)	<input type="text" value="4"/>	<input type="checkbox"/> RF OFF
Step Tuning Delay (ms)	<input type="text" value="1500"/>	<input checked="" type="checkbox"/> Step Tuning
Output Attenuation (0 ~ 31.5 dB)	<input type="text" value="0"/>	<input type="checkbox"/> Hopping

- a. Check Step Tuning check box.

 Step Tuning

- b. Put the start frequency in this box (0.039 ~ 22GHz).

- c. Put the frequency step in this box (GHz)

- d. Put Step Number (Integer).

- e. Put the delay time between each frequency (ms)

- f. Click Transfer data.



## Frequency Hopping Mode

The tuning frequency can follow the tuning table.

- a. Select hopping check box.

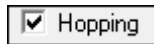

- b. Click hopping table button on the bottom right corner.

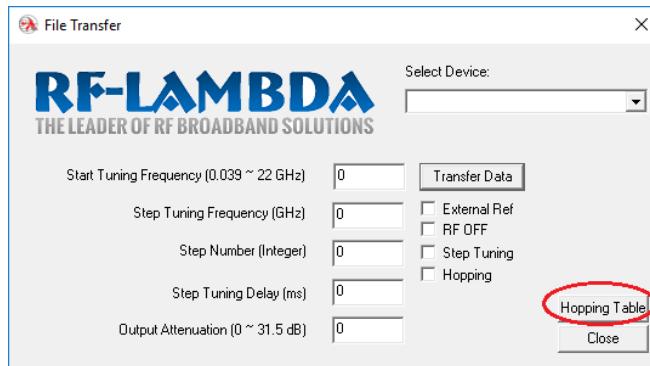

- c. Change the variables in the pop out window, make sure to hit “Enter” ever time after change the values, and input “END” in the finish line after the last hopping frequency.

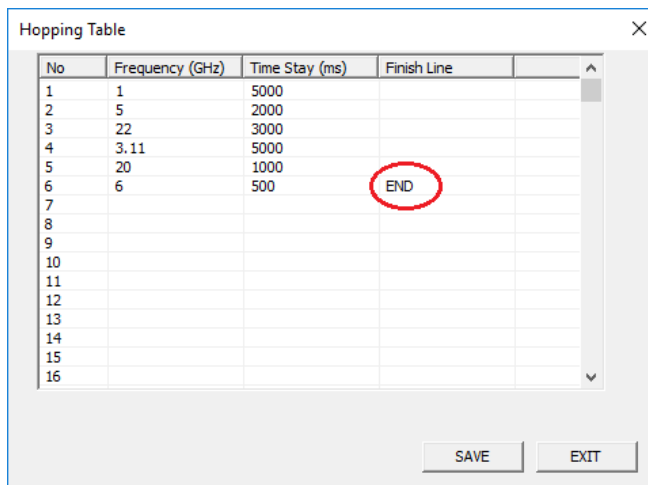



- d. Click the “SAVE” button after finished inputting the data, and then click “EXIT”.

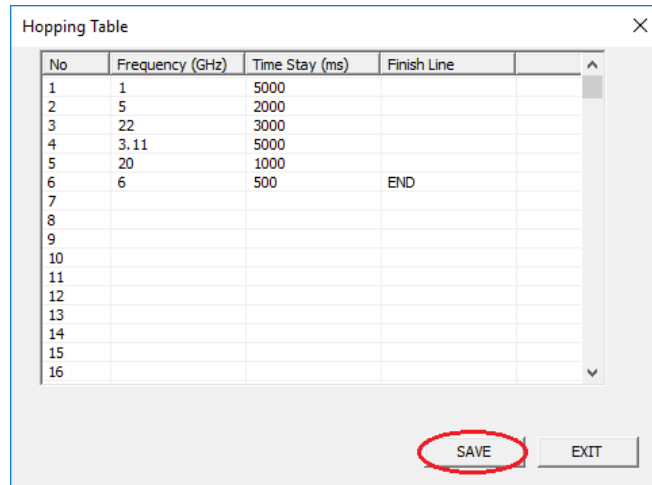

- e. Click “Transfer Data” button start frequency hopping.

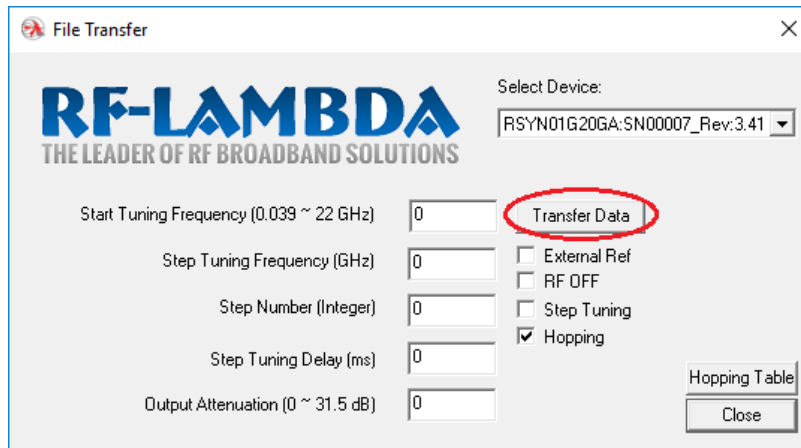





### Outline Drawing:

All Dimensions in mm [inch]

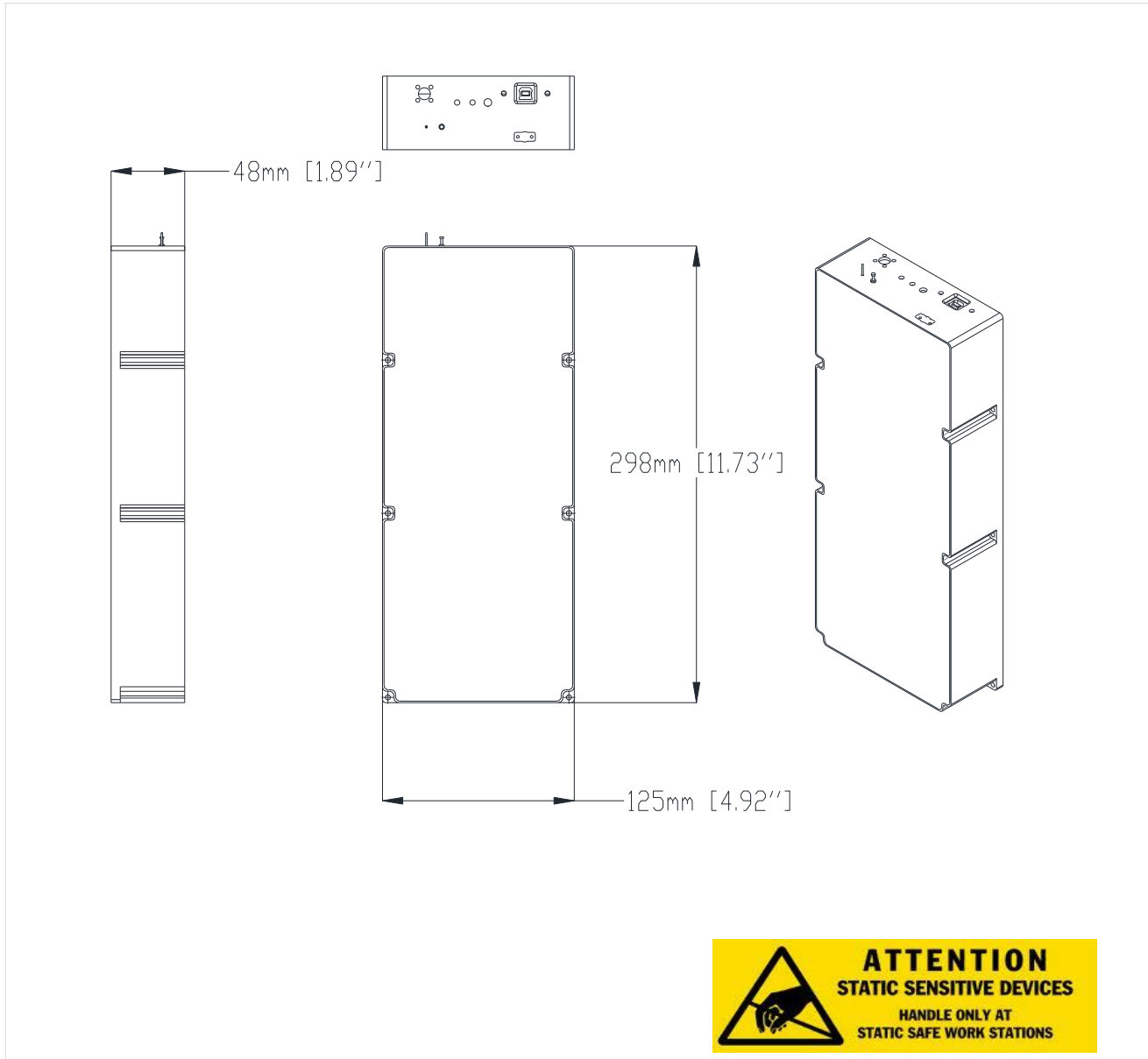

### Important Notice

The information contained herein is believed to be reliable. RF-Lambda makes no warranties regarding the information contained herein. RF-Lambda assumes no responsibility or liability whatsoever for any of the information contained herein. RF-Lambda assumes no responsibility or liability whatsoever for the use of the information contained herein. The information contained herein is provided "AS IS, WHERE IS" and with all faults, and the entire risk associated with such information is entirely with the user. All information contained herein is subject to change without notice. Customers should obtain and verify the latest relevant information before placing orders for RF-Lambda products. The information contained herein or any use of such information does not grant, explicitly or implicitly, to any party any patent rights, licenses, or any other intellectual property rights, whether with regard to such information itself or anything described by such information.

RF-Lambda products are not warranted or authorized for use as critical components in medical, life-saving, or life sustaining applications, or other applications where a failure would reasonably be expected to cause severe personal injury or death.