



### Coaxial Adapter 1.0mm Female to 1.0mm Male DC - 110GHz



Note: Photo is for illustration purposes only.  
Please refer to the outline drawing.

#### Features

- Wide band operation
- Low VSWR
- 50 Ohm Matched

#### Typical Applications

- Enables Between Series Connections
- Test and Measurement

#### Electrical Specifications, TA = +25 °C

Parameter		Min	Typ	Max	Units
Frequency Range		DC		110	GHz
VSWR				1.5	: 1
Impedance		50			Ohms
Polarity		Standard			
Mating Cycles		500			
Connectors	Connector1	1.0mm Female			
	Connector2	1.0mm Male			
Contact	Material	Beryllium Copper			
	Plating	Nickel over Gold			
	Plating Spec	40 µin minimum			

#### Environmental Specifications and Test Standards

Parameter	Standard	Description
Operational Temperature	MIL-STD-39016	-40°C~+70°C
Storage Temperature		-55°C~+125°C
Thermal Shock		1 Hour@ -45°C → 1 Hour @ +85°C (5 Cycles)
Random Vibration		Acceleration Spectral Density 6 (m/s) Total 92.6 RMS
Electrical & Temperature Burn In		Temperature +85°C for 72 Hours
Shock		1. Weight >20g, 50g half sine wave for 11ms, Speed variation 3.44m/s 2. Weight <=20g, 100g Half sine wave for 6ms, Speed variation 3.75m/s 3. Total 18 times (6 directions, 3 repetitions per direction).
Altitude		Standard: 30,000 Ft (Epoxy Sealed Controlled Environment) Optional: Hermetically Sealed (60,000 ft. 1.0 PSI min)
Hermetically Sealed (Optional)	MIL-STD-883	MIL-STD-883 (For Hermetically Sealed Units)

Coaxial Adapter 1.0mm Female to 1.0mm Male DC - 110GHz



Typical Performance Plots

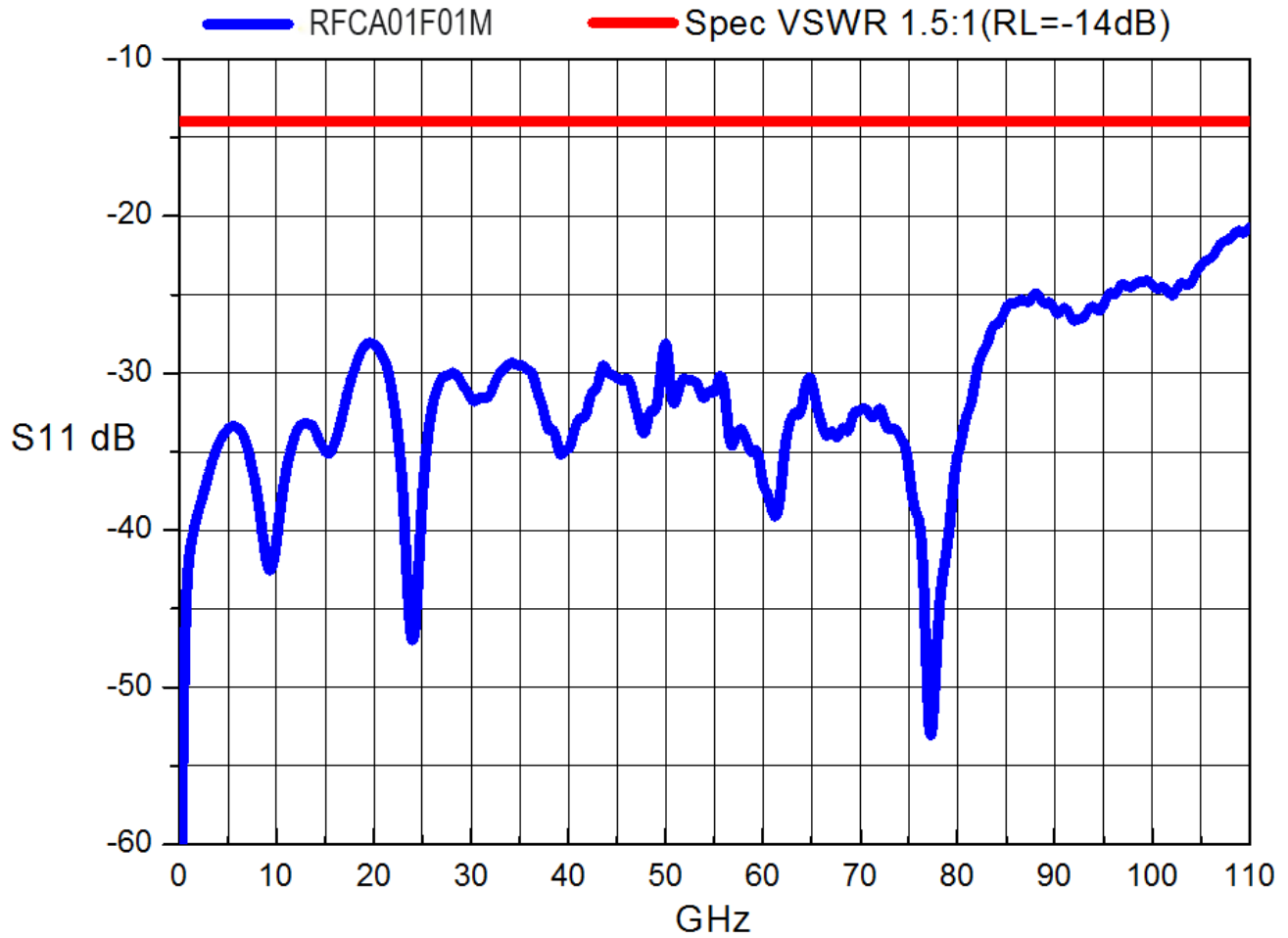

**Coaxial Adapter 1.0mm Female to 1.0mm Male DC - 110GHz**



**Outline Drawing:**

All Dimensions in mm [inches]

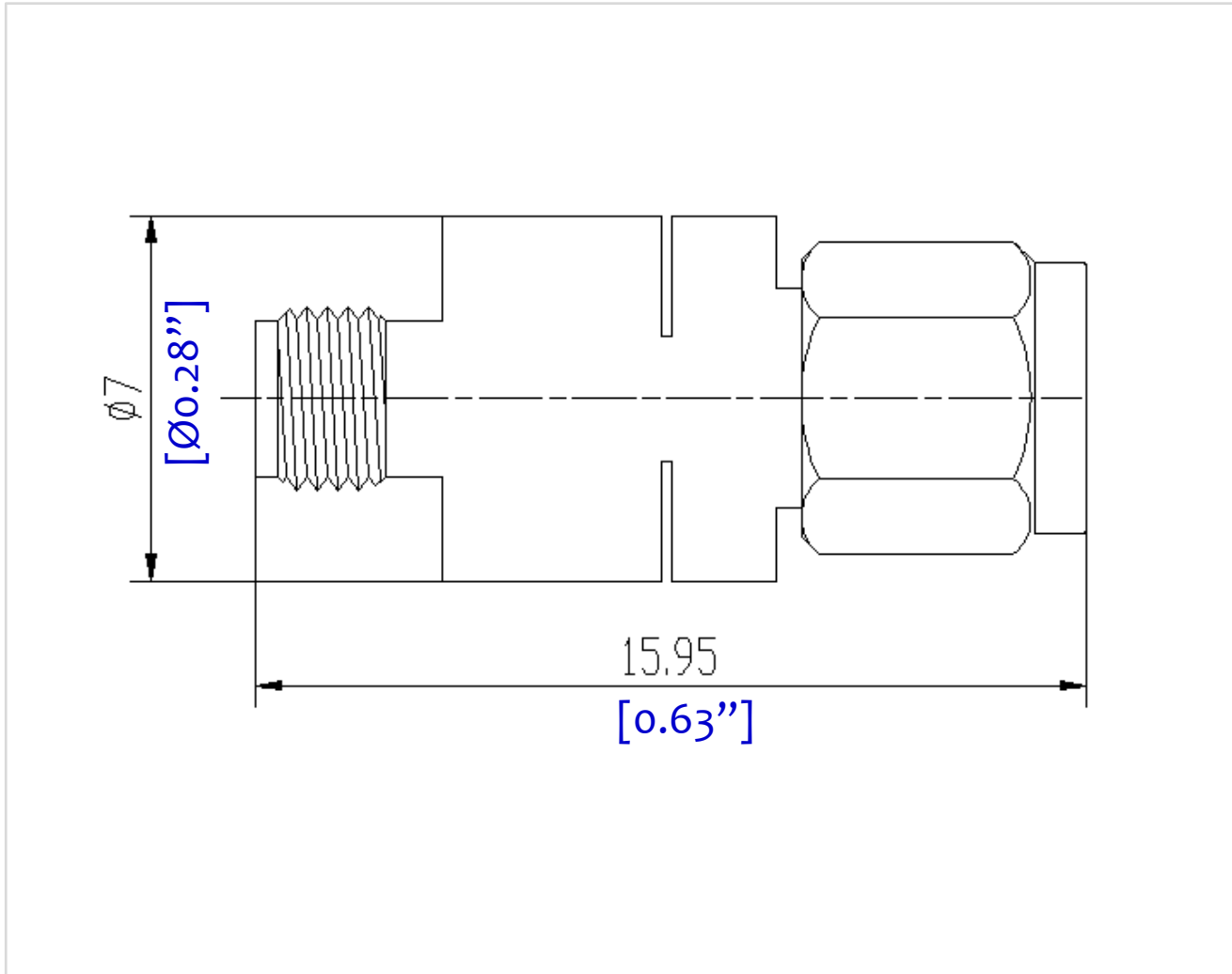

**Important Notice**

The information contained herein is believed to be reliable. RF-Lambda makes no warranties regarding the information contained herein. RF-Lambda assumes no responsibility or liability whatsoever for any of the information contained herein. RF-Lambda assumes no responsibility or liability whatsoever for the use of the information contained herein. The information contained herein is provided "AS IS, WHERE IS" and with all faults, and the entire risk associated with such information is entirely with the user. All information contained herein is subject to change without notice. Customers should obtain and verify the latest relevant information before placing orders for RF-Lambda products. The information contained herein or any use of such information does not grant, explicitly or implicitly, to any party any patent rights, licenses, or any other intellectual property rights, whether with regard to such information itself or anything described by such information. RF-Lambda products are not warranted or authorized for use as critical components in medical, life-saving, or life sustaining applications, or other applications where a failure would reasonably be expected to cause severe personal injury or death.