

WR22 FLANGE STANDARD:UG_COVER/GROOVE[RND]

1.0 ELECTRICAL SPECIFICATIONS		
1.1	Frequency Range	33-50GHz
1.2	Waveguid Type	RectaugularWR22/WG23
1.3	Flange	UG_COVER/GROOVE

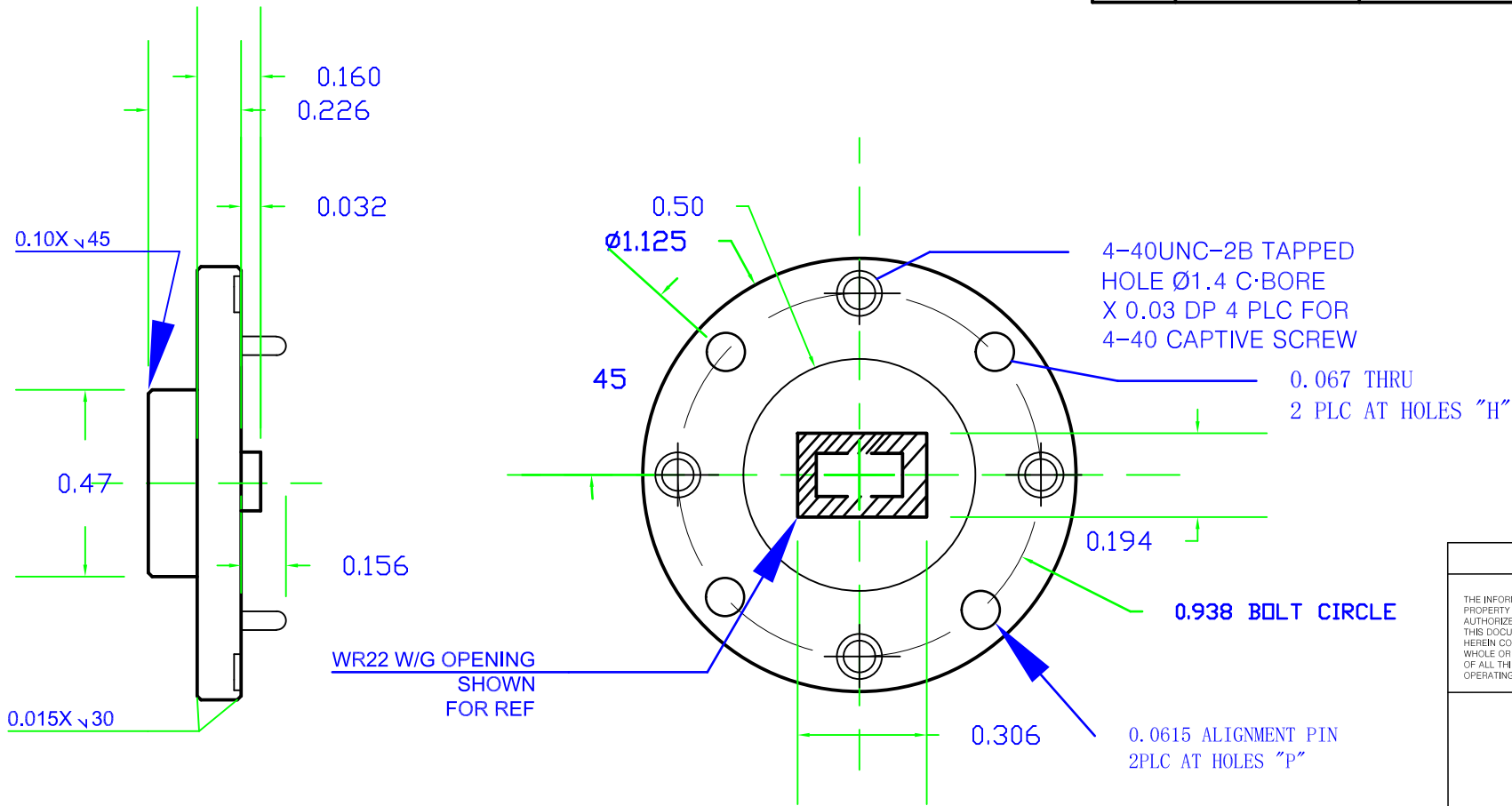

PAGE OF		DATE
19		DESIGN
RF-LAMBDA		RFPC
RF-LAMBDA		RFPC
WR22 FLANGE COVER		CAD MODEL REVISION 19
ASSEMBLY REVISION VS52		ASSEMBLY REVISION VS52
ASSEMBLY NAME RFLVR17		ASSEMBLY NAME RFLVR17
DRAWING NUMBER D05-1		DRAWING NUMBER D05-1
www.rflambda.com		
RF-LAMBDA	SIZE LT	SHEETS 1 OF 1