



Absorptive / Reflective 0.02-1GHz SP8T Switch



- Wide Band Operation 0.02-1.0GHz
- High Power Handle Capability from 0.2W CW to 200W upon request.
- TTL compatible driver include
- Fast Switching Speed
- Low Insertion Loss and High Isolation
- Temperature Range -40°C~+85°C
- Customization available upon request

Absorptive SP8T- Single Pole Eight Throw						
Part Number	Frequency (GHz)	Insert. Loss (dB)	VSWR (Max:1)	Isolation min (dB)	Avg. Power Handling (Watts)	Switching Speed (ns)
RFSP8TA0001G	0.02-1.0	2.0	1.5	70	0.2-1	100-500
Reflective SP8T- Single Pole Eight Throw						
Part Number	Frequency (GHz)	Insert. Loss (dB)	VSWR (Max:1)	Isolation min (dB)	Avg. Power Handling (Watts)	Switching Speed (us)
RFSP8TR0001G	0.02-1.0	1.8	1.5	70	1-200	0.5-10

Environment specifications	
Altitude	45000 ft
Vibration	10g rms (15 degree 2KHz)
Humidity	100% RH at 35c, 95%RH at 40 deg c
Shock	20G for 11msc
PIN define	PIN 1:+5V PIN 2:-5V PIN 3: GND PIN 4:C1 PIN 5:C2 PIN 6:C3 PIN 7,8,9 N/A

C3	C2	C1	ON
0	0	0	J0 → J1
0	0	1	J0 → J2
0	1	0	J0 → J3
0	1	1	J0 → J4
1	0	0	J0 → J5
1	0	1	J0 → J6
1	1	0	J0 → J7
1	1	1	J0 → J8

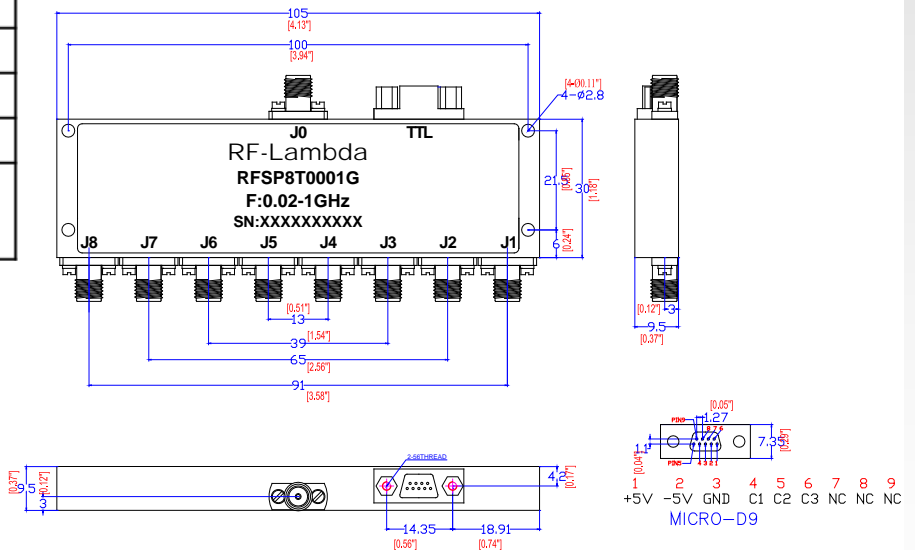

Absorptive / Reflective Coaxial Single Pole Eight Throw Switch 0.02GHz-1.0GHz