

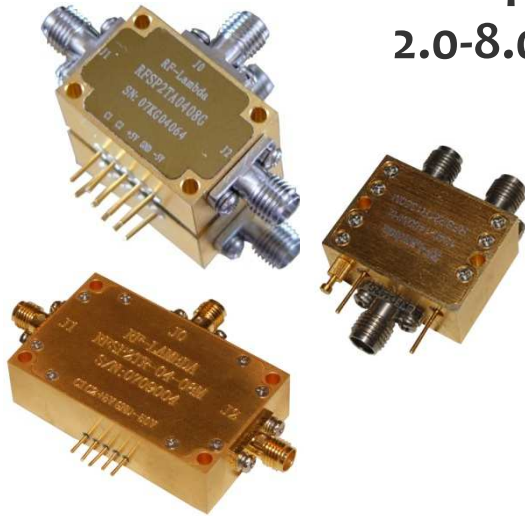

Absorptive and Reflective 2.0-8.0GHz Coaxial SP2T



Features

- Wide Band Operation 2.0-8.0GHz
- High Power Handle Capability up to 10W upon request.
- TTL compatible driver include
- Fast Switching Speed
- Low Insertion Loss and High Isolation
- Temperature Range -40°C~+85°C
- Customization available upon request

Absorptive SP2T- Single Pole Double Throw						
Part Number	Frequency (GHz)	Insert. Loss (dB)	VSWR (Max:1)	Isolation min (dB)	Avg. Power (Watts)	Switching Speed (ns)
RFSP2TA0208G	2-8	2.0	1.8	60	1~5	50~500
Reflective SP2T- Single Pole Double Throw						
Part Number	Frequency (GHz)	Insert. Loss (dB)	VSWR (Max:1)	Isolation min (dB)	Avg. Power (Watts)	Switching Speed (ns)
RFSP2TR0208G	2-8	1.8	2.0	60	5~10	500~2000

Mechanical Specification

Case Style: W201, W202, W203 type.
 Finishing: Gold plating for brass material
 Other finishing available
 Connector: SMA-F Per MIL-C-39012
 Control PIN: 0.02" dia x 0.15" solder pins
 Weight: 20 grams max.
 Mounting: (4) 0.1" dia through holes

Electrical Operation

DC Biasing:
 +5.0V (+/-0.5V 30mA max.)
 -5.0V (+/-0.5V 30mA max.)
 High Voltage Biasing is required for high RF power model.

TTL Logic Control:

C1	C2	
0	0	OFF
0	1	J0->J1
1	0	J0->J2

Power Handle: 0.2W~10W (upon request)



RF-LAMBDA

The power beyond expectations

2-8GHz PIN SP2T

Absorptive / Reflective Coaxial Single Pole Double Throw Switch 2.0-8.0GHz

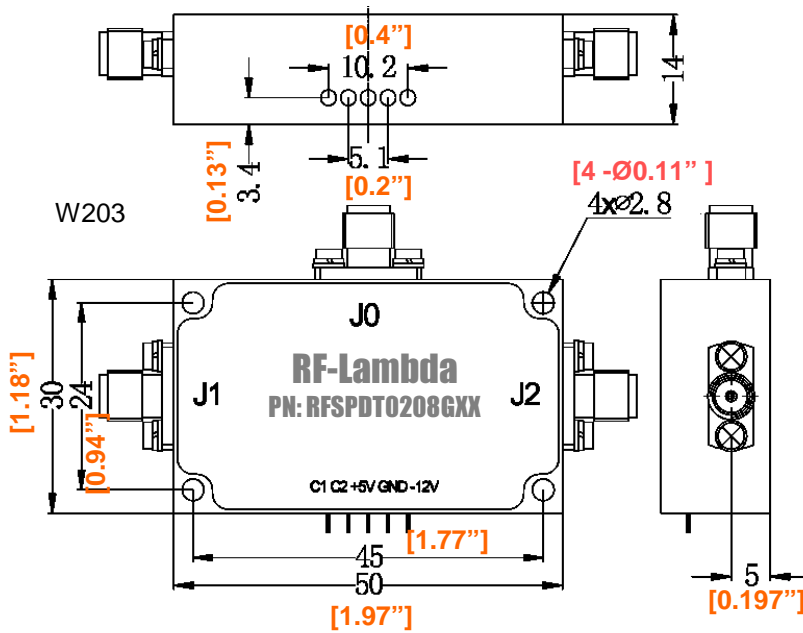
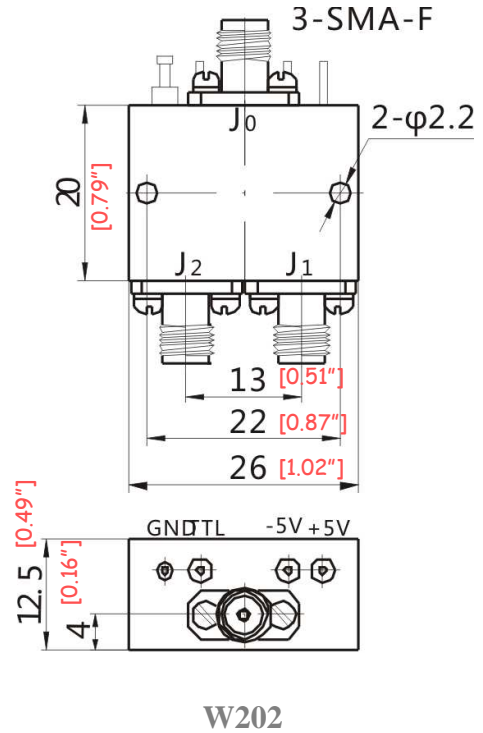
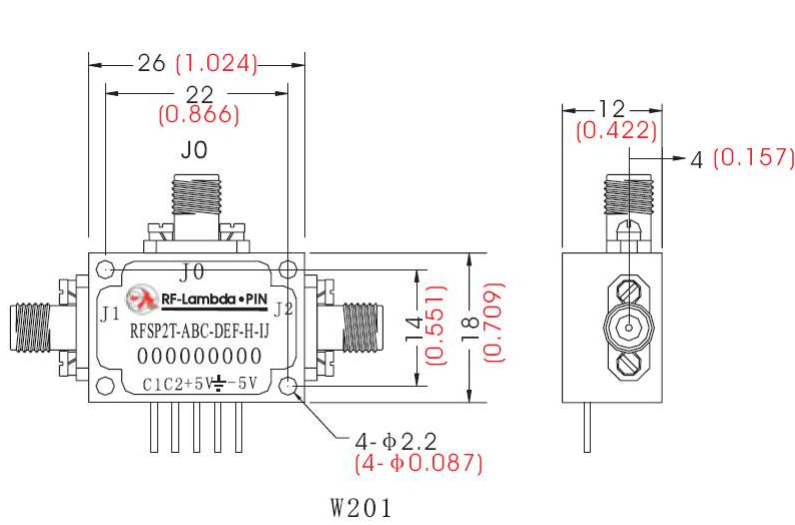

Note: Contact RF-Lambda for faster switching speed, higher power handle, higher isolation

1.Higher power handle capability will give lower isolation , higher biasing current and slower switching speed.

2.Narrower frequency band will improve insertion loss and isolation.