

Wide band Power Limiter 8GHz-18GHz



Product Description

RFPLT08G12G is a wideband power limiter with a frequency range of 8 to 18GHz.

The max peak power of the limiter is 20W. The typical insertion loss is 1.2 dB and Flat Leakage is 17dB.

The power limiter's connectors are SMA-Male and SMA-Female .

The operating temperature of this product is -40 to +85°C.

Features

- Wide Band Operation 8-12GHz
- Functional Bandwidth : 8GHz to 18GHz
- Passive, High Isolation Limiter
- Low Insertion Loss and Good Return Loss
- High Power Handling: 20W

Typical Applications

- Wireless Infrastructure
- Military and Aerospace Applications
- Test Instrumentation
- Radar Systems
- 5G Wireless Communications
- Microwave Radio Systems
- TR Modules
- Research and Development
- Cellular Base Stations

Electrical Specifications (T_A=+25°C)

Parameter	Min	Typ	Max	Min	Typ	Max	Units
Frequency Range	8		12	8		18	GHz
CW Input Power			6			6	CW
Peak Power (30us with 5% duty cycle)			20			20	W
Insertion Loss		1.2	1.5		1.7	2.0	dB
VSWR		1.3	1.6		1.5	1.8	: 1
Flat Leakage		17	20.5		17	20.5	dBm
Peak Power Leakage		20	25		20	25	dBm
Weight			0.03Max.				lbs.
Input / Output Connectors			SMA-Male(Input) - SMA-Female(Output)				
Package			Epoxy Sealed (Standard)				
			Hermetically Sealed (Optional)				

Environmental Specifications and Test Standards

Parameter	Description
Operational Temperature	-40°C to +85°C (Case Temperature)
Storage Temperature	-50°C to +105°C
Thermal Shock	-40°C → +85°C (5 Cycles / 10 hours)
**Random Vibration	MIL-STD-202G Table 214-I, Test Condition Letter C 1.5 Hours Per Axis
High Temperature Burn In	Temperature +85°C for 72 Hours
Shock	1. Weight >20g, 50g half sine wave for 11ms, Speed variation 3.44m/s 2. Weight <=20g, 100g Half sine wave for 6ms, Speed variation 3.75m/s 3. Total 18 times (6 directions, 3 repetitions per direction).
Altitude	Standard: 30,000 Ft (Epoxy Sealed Controlled Environment) Optional: Hermetically Sealed (60,000 ft. 1.0 PSI min)
Hermetically Sealed (Optional)	MIL-STD-883 (For Hermetically Sealed Units)

Typical Performance Plots

Insertion Loss @+25°C

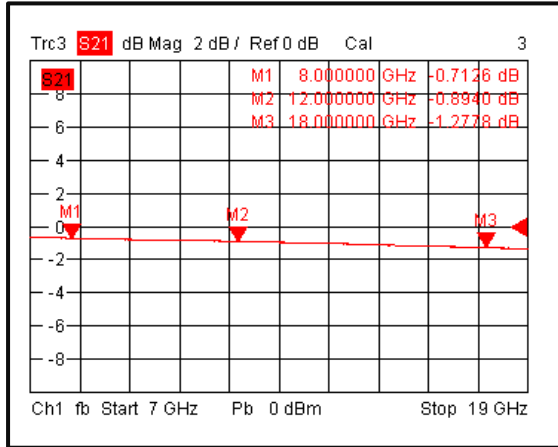

Input VSWR @+25°C

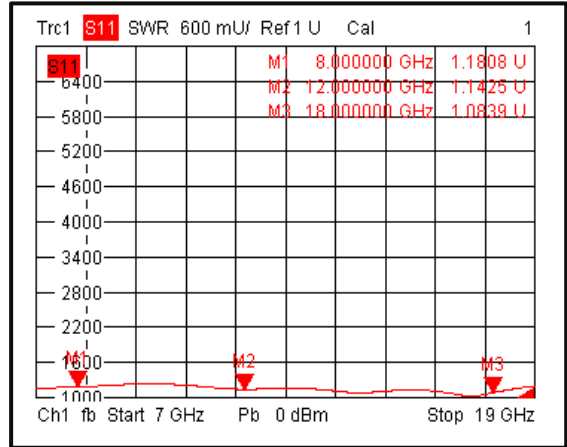

Output VSWR @+25°C

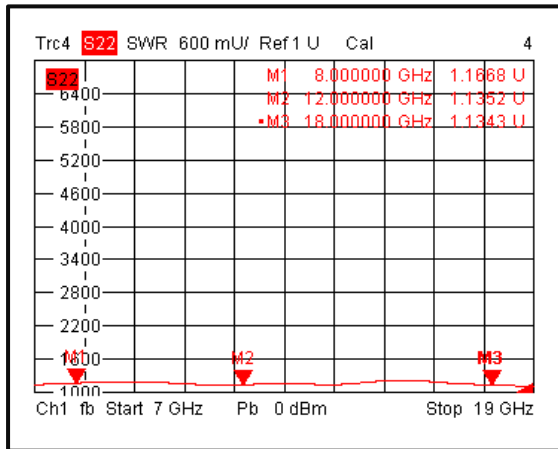

Insertion Loss @-40°C

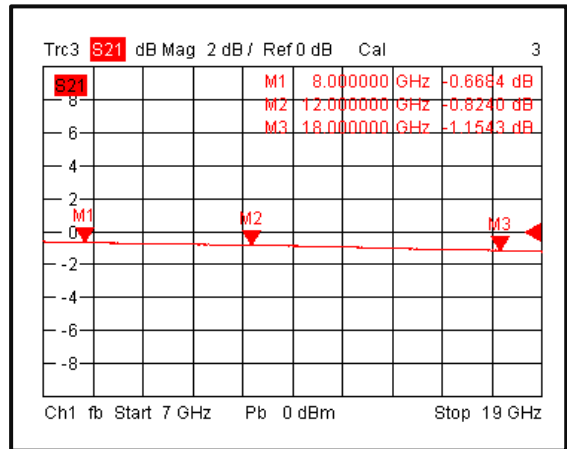

Input VSWR @-40°C

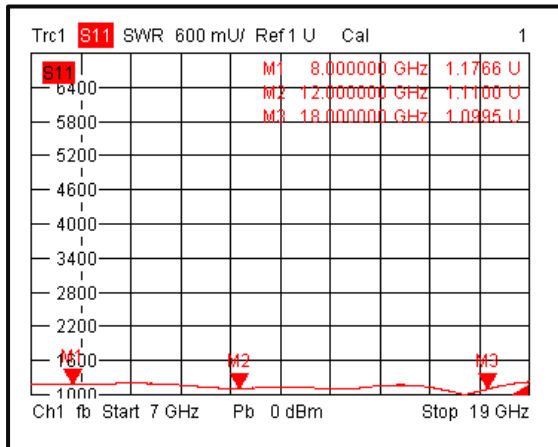

Output VSWR @-40°C

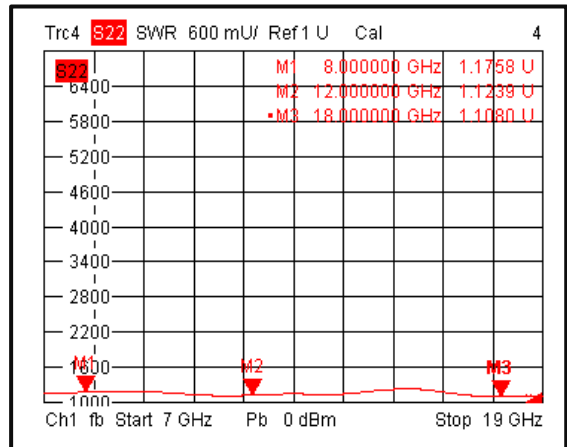

Typical Performance Plots

Insertion Loss @+85°C

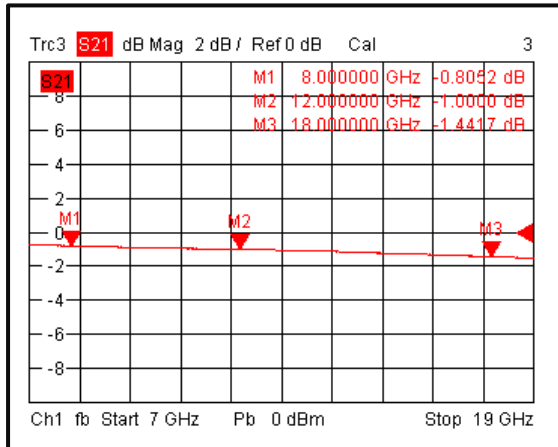

Input VSWR @+85°C

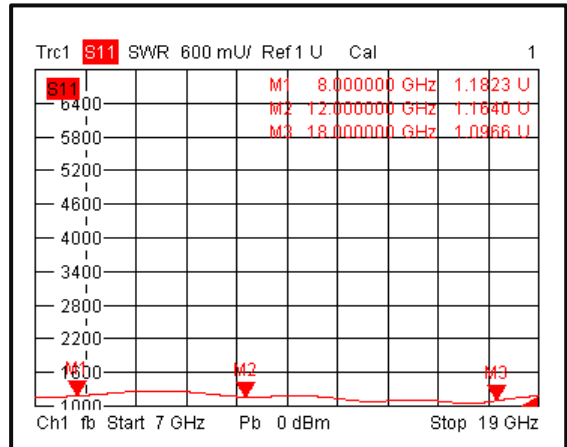

Output VSWR @+85°C

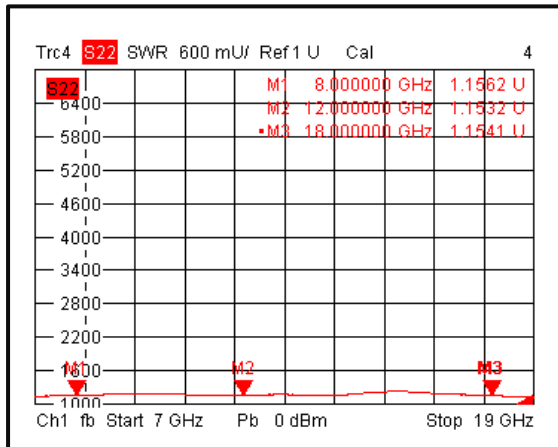

Flat Leakage Power

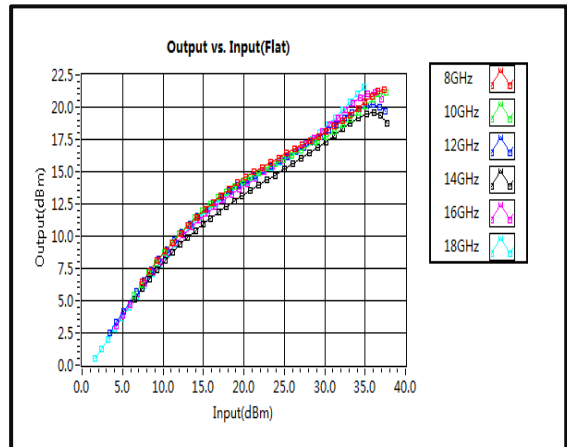

Peak Power Leakage

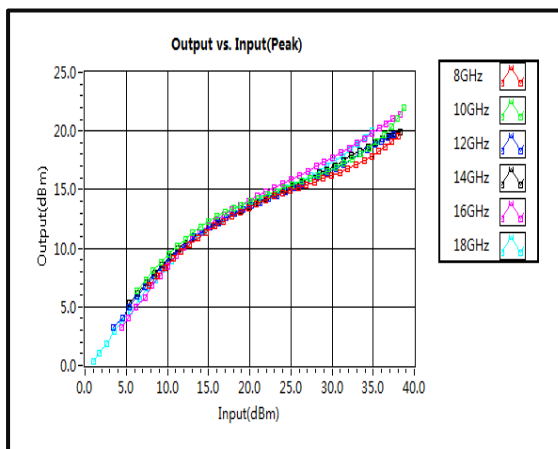

Speed

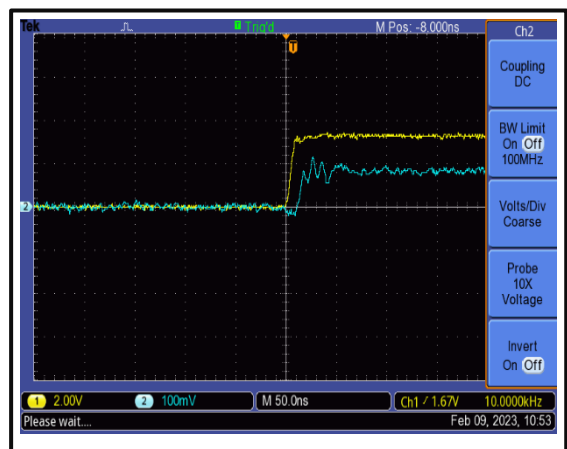

Typical Performance Plots

Speed



Outline Drawing

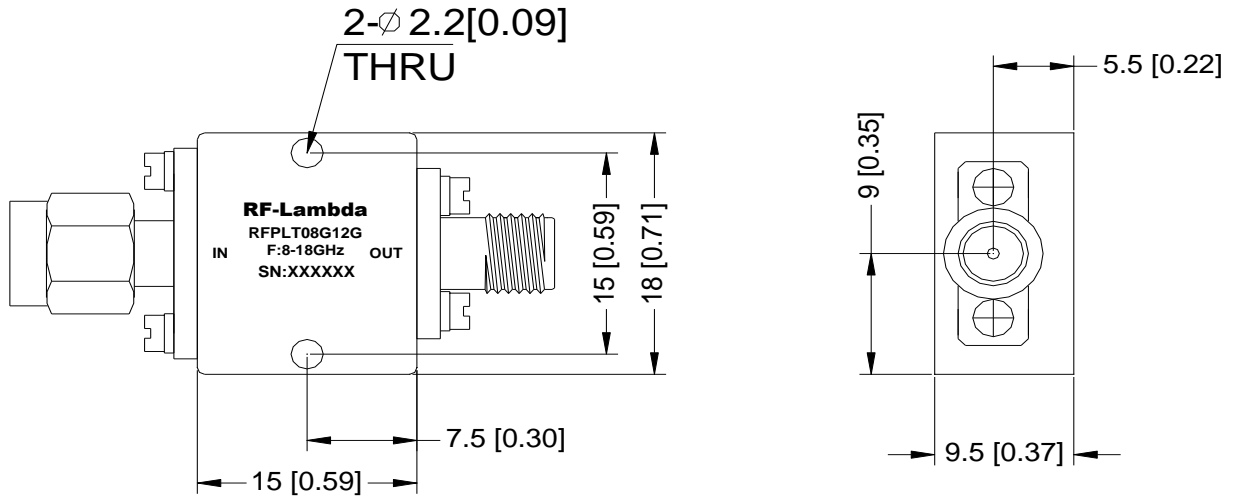

Notes:

1. Package Material: Aluminum
2. Finish: Gold Plated
3. All dimensions are in millimeters [inches].
4. Housing Tolerances ± 0.1 [0.004] unless otherwise specified.
5. Standard torque wrench must be used to secure RF connectors.

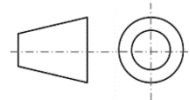

Additional Information

Documentation	Webpage
ESD Policy	https://rflambda.com/pdf/rflambda_esd_control.pdf
Connector Torque Specifications	https://www.rflambda.com/pdf/Torque_Specifications.pdf
Random Vibration Test Standard	https://www.rflambda.com/pdf/rflambda_random_vibration_MIL-STD-202G.pdf

Ordering Information

Part Number	Modification	Description
RFPLT08G12G	Input Connector SMA-Male and Output Connector SMA-Female	8GHz-18GHz Power Limiter

Important Notice

The information contained herein is believed to be reliable. RF-Lambda makes no warranties regarding the information contained herein. RF-Lambda assumes no responsibility or liability whatsoever for any of the information contained herein. RF-Lambda assumes no responsibility or liability whatsoever for the use of the information contained herein. The information contained herein is provided "AS IS, WHERE IS" and with all faults, and the entire risk associated with such information is entirely with the user. All information contained herein is subject to change without notice. Customers should obtain and verify the latest relevant information before placing orders for RF-Lambda products. The information contained herein or any use of such information does not grant, explicitly or implicitly, to any party any patent rights, licenses, or any other intellectual property rights, whether with regard to such information itself or anything described by such information.

RF-Lambda products are not warranted or authorized for use as critical components in medical, life-saving, or life sustaining applications, or other applications where a failure would reasonably be expected to cause severe personal injury or death.