



RF-LAMBDA

The power beyond expectations

RSHB15M03GV



80W 1.5-3.0GHz 90° Hybrid Coupler

Summary:

- . High power operational up to 200W CW
- . Small compacted package
- . Wide bandwidth, flat frequency response
- . MIL-E-5400 standard

Electrical and Environmental Specifications:

Frequency Range:	1.5-3.0GHz
Insertion Loss:	0.35dB
Isolation:	18dB
Amplitude Unbalance:	± 0.5dB
Phase unbalance:	± 2.5 degree
Power:	80W CW
VSWR:	1.30 : 1
Operational Temp. Range:	-55°C~+100° C
Storage Temp. Range:	-55°C~+125° C

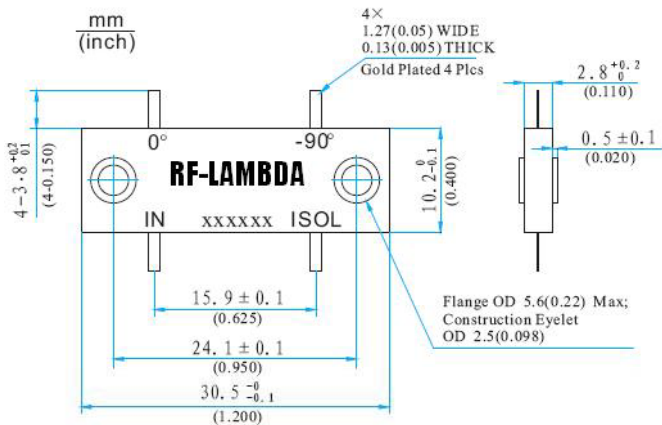

Coupling

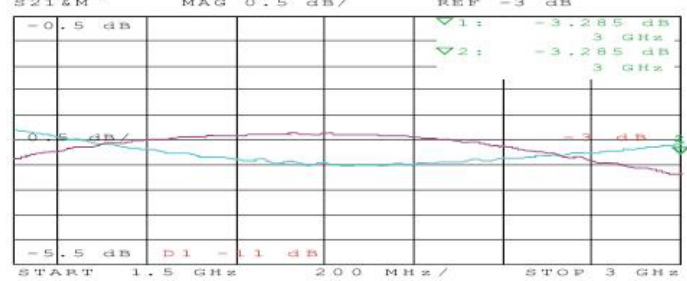

Isolation

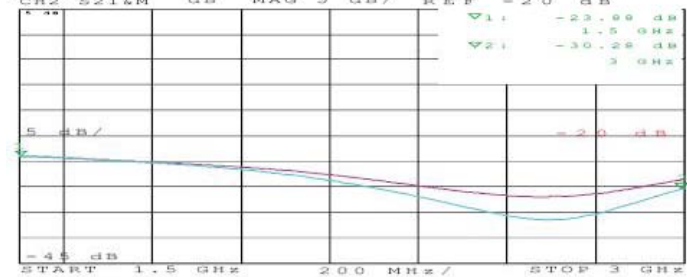

Phase Balance

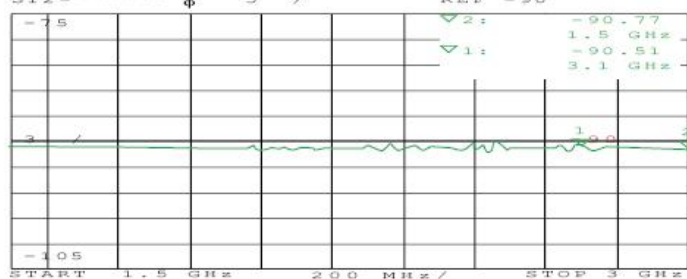

VSWR(Input)



VSWR(Output)

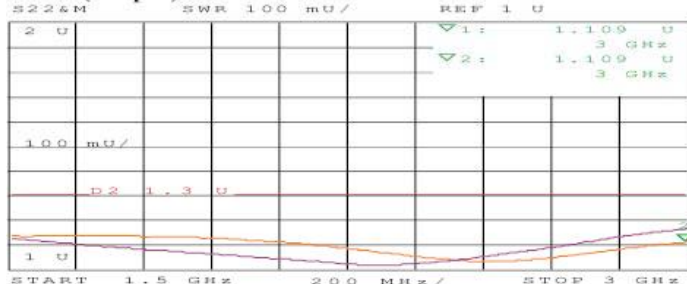

Surface Mount 80W 1.5-3.0GHz 90° Hybrid Coupler