

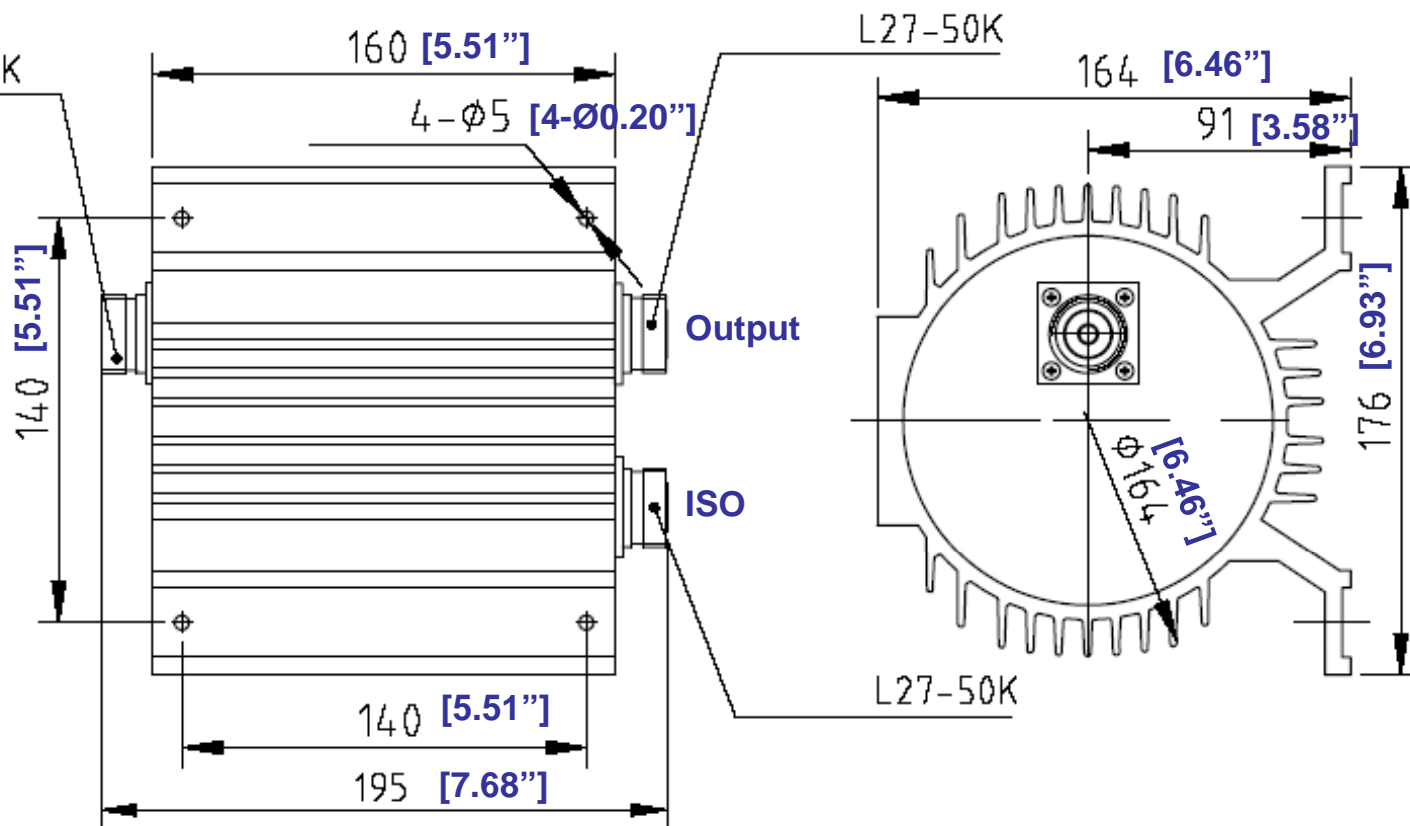

HIGH POWER LUMPED ELEMENTS CIRCULATOR--- RFLC-HXD-11



1.0 Mechanical Specifications		
1.1	Coaxial Connector	7/16 OR N Female
1.2	External Body Finish	Body painted with gray/black epoxy enamel

2.0 Environment specifications		
2.1	Operation Temp.	+10°C~+70°C
2.2	Storage Temp.	-50°C~+125°C
2.3	Altitude	45000 ft
2.4	Vibration	10g rms (15 degree 2KHz)
2.5	Humidity	100% RH at 35c, 95%RH at 40 deg c
2.6	Shock	20G for 11msc

3.0 Electrical Specifications		
3.1	Center Frequency	45MHz~130MHz
3.2	Bandwidth	10MHz
3.3	Insertion Loss	0.8dB
3.4	Isolation	20dB
3.5	Max. VSWR	1.20:1
3.6	Power handle (CW)	500W

PAGE 1 OF 1		DATE	Nov 5 th 2001
<small>PROPRIETARY INFORMATION THE INFORMATION CONTAINED IN THIS DOCUMENT IS THE PROPERTY OF RF-LAMBDA EXCEPT AS SPECIFICALLY AUTHORIZED IN WRITING BY RF-LAMBDA. THE HOLDER OF THIS DOCUMENT SHALL KEEP ALL INFORMATION CONTAINED HEREIN CONFIDENTIAL AND SHALL PROTECT SAME IN THE WHOLE OR IN PART FROM DISCLOSURE AND DISSEMINATION OF ALL THIRD PARTIES AND SHALL USE SAME FOR OPERATING AND MAINTENANCE PURPOSES ONLY</small>		DESIGN	RFPFC
		RF-LAMBDA	RFPFC
		CAD MODEL REVISION	19
		ASSEMBLY REVISION	V552
 RFLC-HXD-11 HIGH POWER CIRCULATOR		ASSEMBLY NAME	RFLVR17
		DRAWING NUMBER	D05-1
www.rflambda.com		SIZE	SHEETS
RF-LAMBDA		LT	1 OF 1